

STAND LENGTH NOTES  
 STANDARD LENGTH = 2.25"  
 STANDS AVAILABLE IN 0.125" INCREMENTS  
 MINIMUM LENGTH IS 1.50"  
 MAXIMUM LENGTH IS 4.00"  
 CUSTOM LENGTHS AVAILABLE ON REQUEST

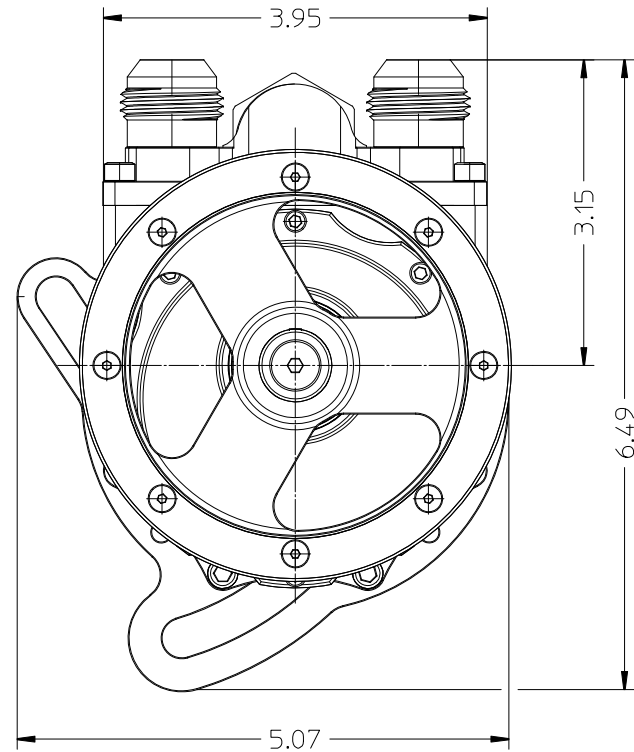

PULLEY	A DIMENSION WITH 2.25" STAND	A DIMENSION (PULLEY REVERSED) WITH 2.25" STAND	B DIMENSIONS (PULLEY DIAMETERS)
GEN1 36T ALUMINUM PULLEY STR.02.07.008 (SHOWN)	5.37"	5.81"	4.45"
GEN1 24T ALUMINUM PULLEY STR.03.12.000	5.37"	5.81"	4.45"
GEN2 24T ALUMINUM PULLEY STR.03.12.000	5.37"	5.81"	4.45"
GEN3 24T ALUMINUM PULLEY STR.20.06.100	5.65"	5.54"	4.45"
ALL COMPOSITE PULLEYS 24T 36T 40T	5.65"	NOT POSSIBLE	24 TOOTH = 3.14" 36 TOOTH = 4.45" 40 TOOTH = 5.00"

2					
1					
0					
REV.	REVISION DESCRIPTION				DATE
	<b>STAR MACHINE</b> 7810 OAK AVENUE PARKVILLE, MD. 21234				DESCRIPTION LAYOUT DIMENSIONS, GEN2 STANDARD PUMP WITH REAR MOUNTING BRACKET STR.99.06.10 HEAT TREATING MATERIAL HARDNESS DEPTH DESIGNED BY T HIGDON SURFACE PREPARATION SCALE SHEET 1 OF 1 SIZE B FINISH DRAWING NO.
TOLERANCES UNLESS SPECIFIED 0.05--10 ± 0.005 11--20 ± 0.010 21--30 ± 0.015 31--40 ± 0.020 44--50 ± 0.030 51--100 ± 0.050	ANGULAR 0-90 ± 0.25° 91-180 ± 0.50° 181-270 ± 0.75° 271-360 ± 1.00°	GEOMETRIC (INCHES) 0.05-20 0.005 21--40 0.010 41--50 0.015 51--100 0.020 0.002 0-100 0.015	BREAK ALL EDGES UNLESS SPECIFIED	THIS DRAWING IS THE PROPERTY OF STAR MACHINE. IT SHALL NOT BE DISCLOSED OR COPIED WITHOUT THE WRITTEN AUTHORIZATION OF STAR MACHINE.	STR.03.01.000