



**STR.19.02.000 & STR.19.05.000**  
**GEN 2 SPORTSMAN VACUUM PUMP INSTRUCTIONS**

#### **MOUNTING THE PUMP**

The pump can be mounted by a clamp around the diameter if required. The standard mounting bracket STR.18.12.003 will enable the pump to be mounted to a BBC or SBC cylinder head or any front engine plate.

#### **DRIVING THE PUMP**

There are many pulley/belt tooth configurations available today. We have chosen one of the most commonly found on race cars with .50" wide x .375" (L) pitch belts and pulleys. You may use another style as long as you follow the recommended ratios. If you chose to change the pulley on the Pump, you **MUST** use the pulley thrust cap delivered with your pump! This requires the use of a pulley (or pulley and spacer) with a combined hub width of .85" to .80" to ensure that the thrust cap will not bottom out on the shaft face. Use **ONLY ONE** set screw, directly over the key. Tighten the thrust cap first, then the set screw. Install the Pump pulley with the fins facing the Pump.

#### **PUMP DRIVE RATIOS**

A pump speed of 58% of crankshaft speed is ideal for most applications. There may be some benefit to increasing the Pump speed greater than 58% for large displacement engines turning low RPM. The factors used to determine the ideal drive ratio are engine displacement, engine RPM range, power enhancers such as Nitrous Oxide, supercharger or turbo charger, and the desired level of vacuum. Due to the high efficiency rate of the STAR Machine Pump, a drive ratio slower than 2:1 will provide better results on high RPM applications. Excessive Pump speeds that develop excessive levels of vacuum could be detrimental. Although slower Pump speeds will alleviate this condition, it could create a disadvantage at low RPM's, especially in cars using automatic transmissions. Call STAR Machine for recommendations. The maximum recommended pump speed is 5000 RPM. STAR Machine recommends the use of a vacuum regulator on wet sump engines to address this condition. The regulator can be set at an ideal vacuum level for your particular application, insuring that vacuum levels will not exceed helpful levels. STAR Machine can pre-set your regulator accurately using precision vacuum equipment. This service is provided free of charge for our vacuum pump customers.

#### **PLUMBING THE PUMP**

This Pump is supplied with -12 A/N fittings machined from 7075 series aluminum which are pressed into place. The same considerations should be given to plumbing the Vacuum Pump as you would when plumbing your fuel system. Keep the hose lengths as short as possible. Avoid right angle fittings if possible. Free flowing, large radius bends are best. Use hose and fittings with a minimum I.D. of .65". We recommend, and the Pump is designed for .75" I.D. hose on the intake AND exhaust. The use of springs inside of a hose to prevent from collapsing will disrupt airflow and may become loose and be drawn into the Pump. We recommend (and have available) a see-thru hose designed specifically for high vacuum systems. This hose is an inexpensive alternative to steel braided hose, contains a larger internal diameter for more flow and will give you an early indication if oil is being drawn into the Pump. A/N Push Lock style hose ends are recommended when using our vacuum hose.

#### **VACUUM REGULATION**

Use of a vacuum pump without monitoring the amount of vacuum present is like playing Russian roulette. If you are not using a data recorder to monitor vacuum we recommend the use of a vacuum gauge located where the driver can observe it while racing. We have a wide array of vacuum regulators from which to choose. Visit our web site to determine which regulator best suits your needs.

#### **OPTIMIZING PERFORMANCE**

The most overlooked aspect of successful crankcase vacuum is excessive leakage due to poor gaskets and seals and excessive blow-by. The ideal drive ratio can NEVER be achieved if excess pump speed is necessary to overcome leaks. Even the most careful engine assemblers can take for granted areas they never thought to be a problem. Vacuum or pressure testing the engine for leakage must be done if optimum results are to be realized. Unlike fuel or coolant leaks that are obvious to the eye, vacuum leaks are not visible and consequently assumed to be nonexistent.

#### **\*THINGS TO AVOID\***

##### **\*OIL IN THE PUMP:**

The Pump is an "OIL-LESS" design, which requires NO LUBRICATION for operation. Oil in the Pump will not damage the Pump, however it will reduce its performance. The drier you can keep this Pump, the better it will work! The use of a baffle is mandatory! This may require several modifications to the location and design of the baffle you draw vacuum from. How will you know if oil is in the pump? If you use clear hose and the hose shows signs of oil in it, the oil will be in the Pump also. If you remove the belt from the Pump and spin it by hand and you do not hear the vanes tapping (as they are flung from the rotor) you have oil in the Pump. To clean the oil from the Pump, remove the hose from the intake side of the Pump and spray nonflammable (environmentally safe) solvent into the intake tube with the engine running. Mind the Pump exhaust when doing this! You should make this part of your usual race car maintenance. Excessive oil in the pump is usually a clear indication of a failed seal or gasket.

##### **\*DIRT IN THE PUMP:**

During installation and storage use the caps supplied to cover the intake and exhaust tubes.

##### **\*TOUCHING THE PUMP AFTER A RUN:**

It will be VERY HOT (300+ degrees F).

##### **\*ARTIFICIALLY COOLING THE PUMP:**

Do not blow air, place ice packs or pour water on the Pump to cool it. ALLOW THE PUMP TO COOL NATURALLY

##### **NEVER PLACE OBJECTS IN THE INT. OR EXH. PORTS WHILE THE PUMP IS RUNNING**

( Especially your fingers)

**FOR MORE DETAILED INFORMATION ON ALL OUR PRODUCTS VISIT US AT [STARVACUUMPUMPS.COM](http://STARVACUUMPUMPS.COM)  
STAR MACHINE, 7810 OAK AVENUE, PARKVILLE, MARYLAND 21234  
PHONE: 667.210.3874 FAX: 410.661.2467**

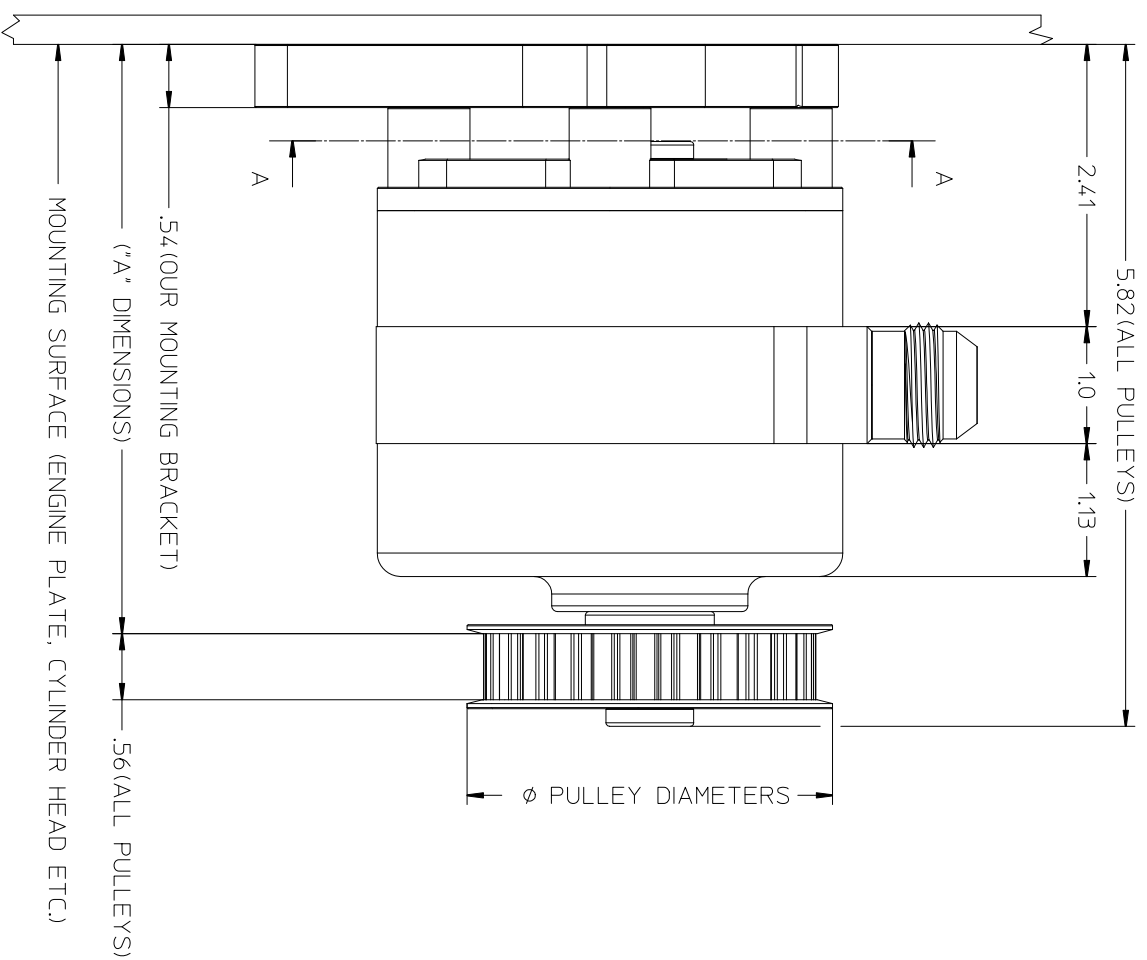

*A* DIMENSIONS WITH OPTIONAL PULLEYS	
WITH 24T COMPOSITE PULLEY STR.99.06.010 (SHOWN)	5.03"
WITH 24T GEN3 ALUMINUM PULLEY STR.20.06.100	5.03"
WITH 24T GEN3 ALUMINUM PULLEY STR.20.06.100 (TURNED AROUND)	4.92"
WITH 36T COMPOSITE PULLEY STR.99.06.011	5.03"
WITH 24T ALUMINUM PULLEY STR.03.12.000	4.75"
WITH 24T ALUMINUM PULLEY STR.03.12.000 (TURNED AROUND)	5.20"
WITH 36T ALUMINUM PULLEY STR.02.07.008	4.75"
WITH 36T ALUMINUM PULLEY STR.02.07.008 (TURNED AROUND)	5.20"

PULLEY DIAMETERS	
24T COMPOSITE PULLEY	3.13"
36T COMPOSITE PULLEY	4.55"
24T ALUMINUM PULLEY	2.98"
36T ALUMINUM PULLEY	4.45"

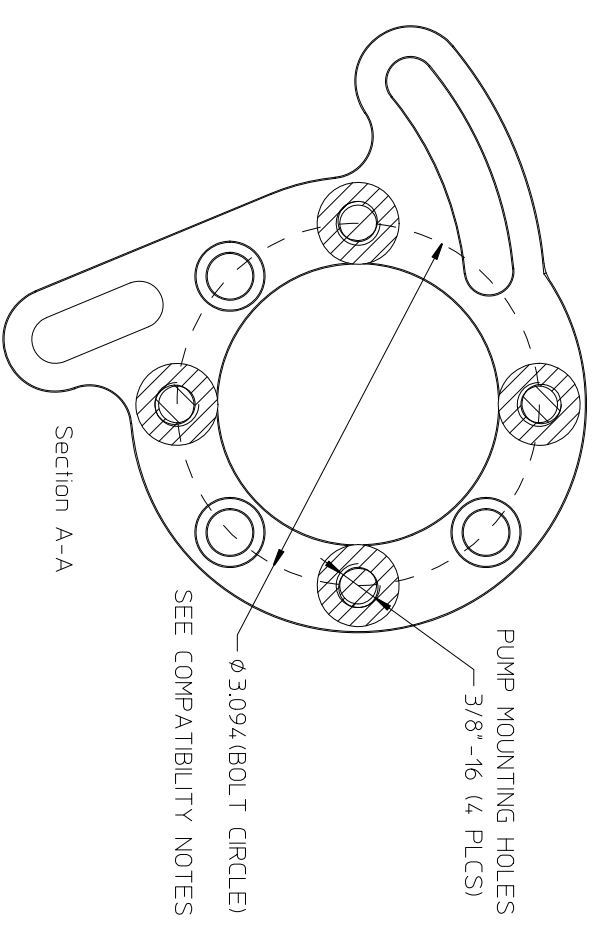
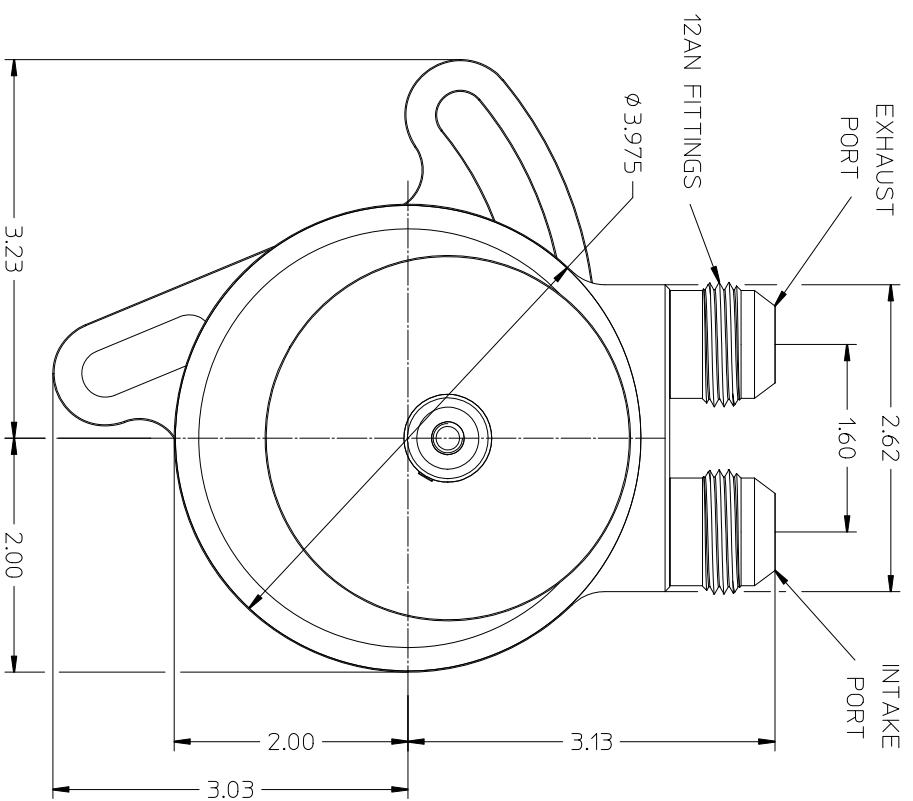

\* BRACKET CAN BE FLIPPED OVER FOR OPPOSITE HAND MOUNTING  
 \* PUMP CAN BE INDEXED ON BRACKET EVERY 45° FOR BEST POSITIONING

PUMP COMPATIBILITY NOTES  
 OUR PUMP CAN BE MOUNTED TO THESE BRACKETS:  
 MOROSO #63909 (BIG BLOCK FORD-DRIVER OR PASSENGER SIDE HEAD)  
 MOROSO #63910 (ENGINE PLATE, SBC/BBC DRIVE OR PASSENGER SIDE HEAD)  
 MOROSO #63911 (SMALL BLOCK FORD HEAD)  
 MOROSO #63912 (BIG BLOCK CHRYSLER -DRIVER SIDE)  
 MOROSO #63922 (GM LS DRIVER SIDE HEAD)  
 MOROSO #63923 (GM LS PASSENGER SIDE HEAD)  
 REHER-MORRISON #828-033 (RMRE BBC PASSENGER SIDE HEAD)  
 REHER-MORRISON #838-030 (RMRE BBC DRIVER SIDE HEAD)

REV.	REVISION DESCRIPTION	DATE
2		
1		
0		

**STAR MACHINE**  
 7810 OAK AVENUE  
 PARKVILLE, MD. 21294

DESCRIPTION: GEN 2 SPORTSMAN PUMP

HEAT TREATING: H

HARDNESS: H

SURFACE PREPARATION: S

FINISH: F

DESIGNED BY: T HIGDON

SCALE: 1 OF 1

SHEET: 1

SIZE: C

DRAWING NO. STR.19.05.000

0.05-.10 ± 0.005  
 .10-.30 ± 0.015  
 .31-.40 ± 0.020  
 .41-.50 ± 0.025  
 .51-.100 ± 0.050

0.05-.10 ± 0.005  
 .10-.30 ± 0.015  
 .31-.40 ± 0.020  
 .41-.50 ± 0.025  
 .51-.100 ± 0.050

91-160 ± 0.250  
 161-210 ± 0.750  
 211-500 ± 1.000

91-160 ± 0.250  
 161-210 ± 0.750  
 211-500 ± 1.000

THE DRAWING IS THE PROPERTY OF STAR MACHINE  
 IT SHALL NOT BE DISCLOSED OR COPIED WITHOUT  
 THE WRITTEN AUTHORIZATION OF STAR MACHINE.