



**12 AN FEMALE VACUUM REGULATOR INSTRUCTIONS  
STR.04.12.000**

**THEORY**

Locating the vacuum regulator outside of the crankcase area and placing it directly onto the vacuum pump is the ideal position. The regulator creates a controlled leak to limit the amount of crankcase vacuum. When such a leak is placed inside the crankcase area it promotes oil to be scavenged from the engine. The pump-mounted regulator not only reduces this condition but also allows ambient air into the pump as opposed to hotter crankcase air when the set point is reached allowing the pump to run cooler.

**INSTALLATION**

The Star Machine pump mounted regulator will work on any manufactures pump containing a -12 AN male thread. Install the regulator onto the vacuum fitting of the pump or on the baffle on the valve cover (which ever gives the best access. If this regulator is being used on the Star Machine EVP (electric vacuum pump) containing AN fittings, install the regulator onto the blue tube. The "banjo" containing the regulator swivels allowing it to float and be rotated 360 degrees for ideal positioning. **During installation, if obstructed, the regulator head can be held from turning while tightening the fitting.** Connect the hose (containing -12 female hose end) coming from the engine to the regulator. The regulator can also be installed onto the top fitting of a Star Machine tank containing A/N fittings or onto a -12 A/N male fitting at the engine.

**ADJUSTING THE REGULATOR SET POINT**

The regulator is filtered, infinitely adjustable, and does not require disassembly to change the set point. To adjust the set point, loosen the 1/4" hex jam nut. Increase vacuum by turning the regulator (the portion containing the screen) in (clockwise). Decrease vacuum by turning the regulator out (counterclockwise). Retighten the jam nut.

**FOR MORE DETAILED INFORMATION ON ALL OUR PRODUCTS VISIT US AT [STARVACUUMPUMPS.COM](http://STARVACUUMPUMPS.COM)**

STAR MACHINE  
7810 OAK AVENUE  
PARKVILLE, MARYLAND 21234

PHONE: 667.210.3874  
FAX: 410.661.2467  
EMAIL: [STARVACUUMPUMPS@GMAIL.COM](mailto:STARVACUUMPUMPS@GMAIL.COM)

CUTAWAY VIEW

ORING - SIZE 021 (2 REQ'D)

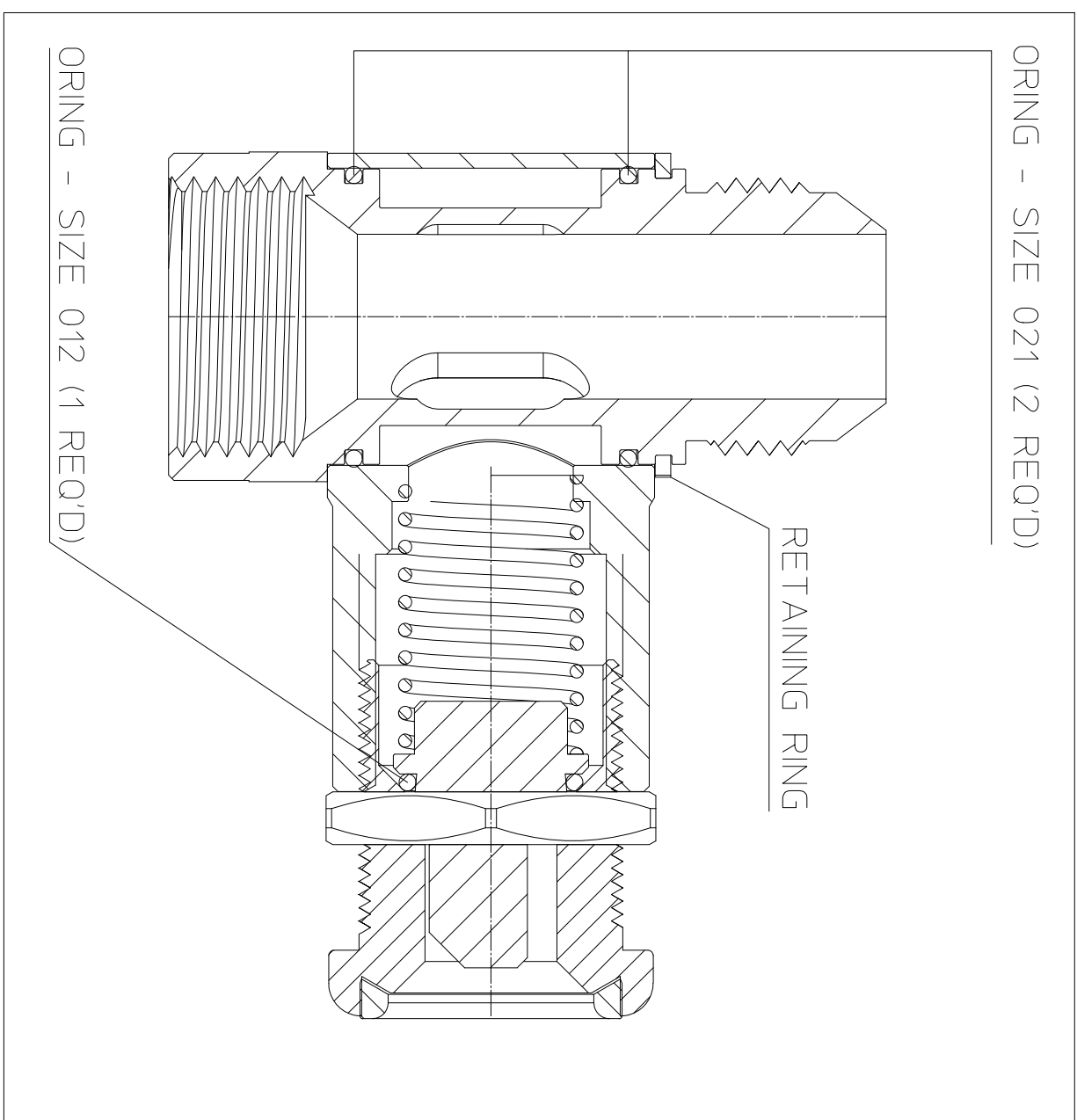
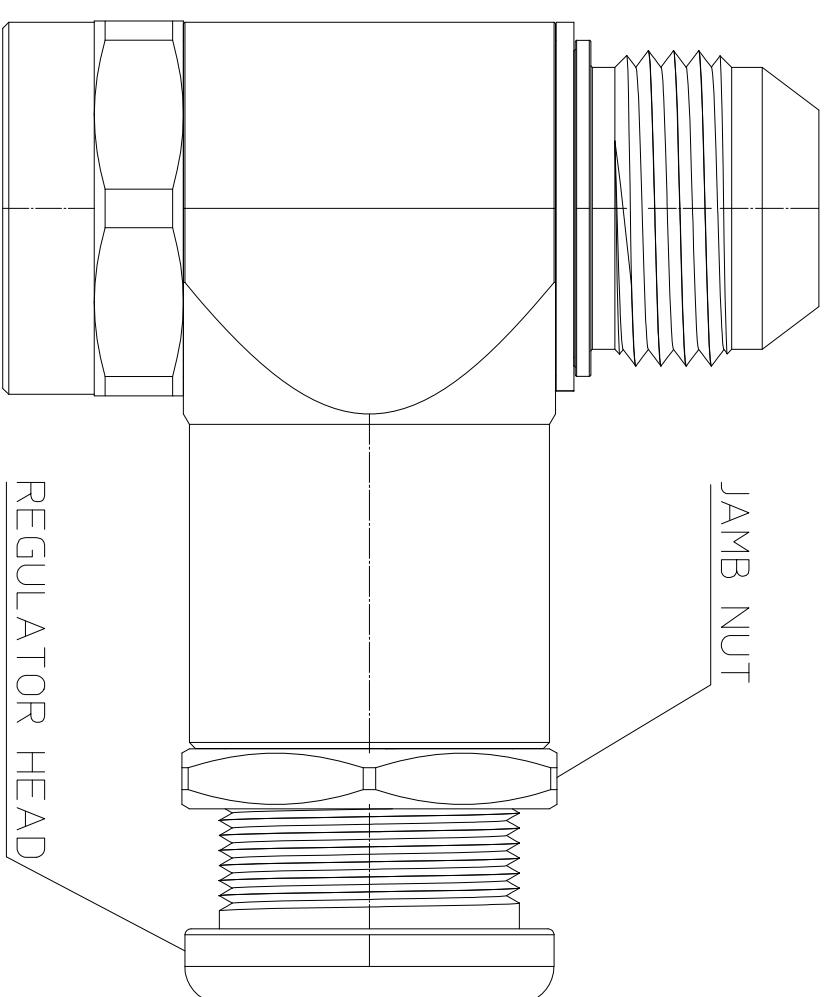

REV.	REVISION DESCRIPTION	DATE
2		
1		
0		

<p><b>STAR MACHINE</b>                  7810 OAK AVENUE                  PARKVILLE, MD. 21234</p>		<p>REVISION DESCRIPTION</p>	
<p>DESCRIPTION</p>		<p>REGULATOR, FEMALE VACUUM</p>	
<p>HEAT TREATING</p>		<p>MATERIAL</p>	
<p>HARDNESS</p>		<p>DESIGNED BY</p>	
<p>DEPTH</p>		<p>T HIGDON</p>	
<p>SURFACE PREPARATION</p>		SCALE	SHEET
<p>FINISH</p>		1 OF 1	B
<p>THIS DRAWING IS THE PROPERTY OF STAR MACHINE. IT SHALL NOT BE DISCLOSED OR COPIED WITHOUT THE WRITTEN AUTHORIZATION OF STAR MACHINE.</p>		<p>DRAWING NO.</p>	
<p>STR.04.12.000</p>			

TOLERANCES UNLESS SPECIFIED

LINEAR (INCHES)	ANGULAR
0.05--10 ± 0.005	0-90 ± 0.25°
11--20 ± 0.010	91-180 ± 0.50°
21--30 ± 0.015	181-270 ± 0.75°
31--40 ± 0.020	271-360 ± 1.00°
41--50 ± 0.030	
51--100 ± 0.050	

BREAK ALL EDGES UNLESS SPECIFIED

LINEAR (INCHES)	ANGULAR
0.05--20 ± 0.005	0-90 ± 0.010
21--40 ± 0.010	91--100 ± 0.015
41--50 ± 0.015	51--100 ± 0.020
51--100 ± 0.030	